



OWNERS MANUAL

Patrol 8MP

CAM-H08-F



www.oztrail.com.au

CONTENTS PAGE

Contents Page	2
Introduction	3
Important Safety Precautions	3
Product Specification	6
Contents	7
Getting to know your Camera	8
Getting Started	10
Camera Operation	15
AV Output	19
Connection to a Computer	20
Troubleshooting	21
Warranty	23

INTRODUCTION

Congratulations on the purchase of your new camera.

This manual contains important safety and operating information. Please read all the information carefully before you use the device to avoid accidents and keep it for future reference. Follow these important safety and operation instructions.

IMPORTANT SAFETY INSTRUCTIONS

- This Product is rated IP54, please ensure it is use within this environment
- Press the buttons gently. Pressing too hard can damage the product.
- Do not subject the camera to heat source or impact to avoid damage.
- Do not attempt to dismantle or repair this camera



yourself. Qualified personnel should perform repairs.

- Disconnect or remove all power source from the camera before cleaning.
- This product is not intended for commercial use. Household/personal use only.
- To prevent software failure, never disconnect the product from a PC while file transferring is in progress
- Keep your camera clean (use a dry soft cloth to clean. Do not use alcohol, thinners or benzene to clean the surface of the product).
- Do not kink USB and video cable and do not install it over sharp edges.
- Keep batteries away from children and pets.
- Insert the batteries observing the proper polarity (+/-). Failure to properly align the battery polarity can cause injury and/or property damage.



- Remove old or discharged batteries from the product.
- Remove the batteries when the product will not be used for extended periods of time to prevent damage due to rusted or corroded batteries.
- Never throw batteries into a fire, do not expose batteries to fire or other heat sources.
- Battery Disposal: Old or discharged batteries must be properly disposed of.
- Keep children away from batteries. If you suspect a battery has been swallowed, seek immediate medical assistance.

Attention: We have done our best to produce a complete and accurate manual. However, we cannot ensure that there are no errors or omissions during the printing process.



PRODUCT SPECIFICATION

- Video Resolution: 720P (1280 x 720 @ 30fps)
- Still Image: 5MP, 8MP
- Status LCD Screen
- IP54
- Triggering Distance: 20m
- Triggering Speed: 0.6secs
- Sensor Angle: 40°
- 34 IR Low Glow LED (850nm)
- Powered by 4 x AA batteries (Can be expanded to 8 x AA Batteries)
- Expandable Micro SD Slot up to 32GB
- Works with Windows XP, Vista, 7, 8, 10, OSX 10.2 and above

NOTE: As a result of continual improvements, the design and specifications of the product within may differ slightly from the unit illustrated on the packaging.



CONTENTS

Please make sure that the items shown below are included in the package. Should an item be missing, please contact the local retailer from which you purchased this product

- | | | |
|----|----------------------------------|---------|
| 1. | Trail Camera | 1 piece |
| 2. | Mounting Bracket and Accessories | 1 piece |
| 3. | Mounting Strap | 1 piece |
| 4. | USB Cable | 1 piece |
| 5. | AV Cable | 1 piece |
| 6. | User Manual | 1 piece |

GETTING TO KNOW YOUR CAMERA

DEVICE OVERVIEW

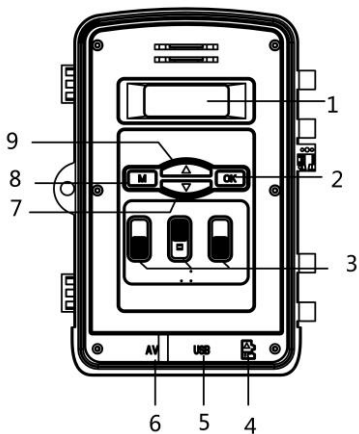

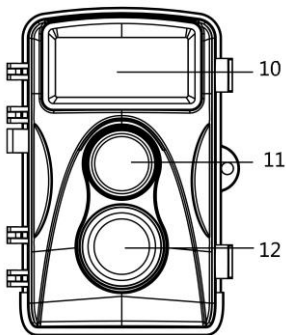

1	LCD Screen	2	OK
3	Mode, Delay, Resolution	4	Micro SD Slot
5	USB Socket	6	AV Output
7	Down	8	Menu
9	Up	10	IR LED
11	Lens	12	IR Sensor

GETTING STARTED

POWER SUPPLY

Please install batteries before using the camera.

Open the camera case and remove the battery cover. Install 8 pieces of 1.5V AA batteries. Please make sure they are inserted as per the (+ and -) symbols.

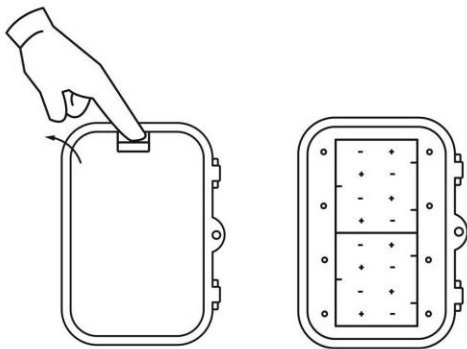

INSERTING MICRO SD CARD

This camera does not have internal memory.

You will need a Class 8 or higher Micro SD card and must be inserted for this camera to operate and record.

1. Turn off the camera
2. Find the Micro SD card slot, and then insert the Micro SD card by pushing it into place.
3. To remove the Micro SD card, push the card again until it partially ejects

Note: Some Micro SD cards may need to be formatted before using; this can be done via your computer.



MOUNTING STRAP

The Mounting strap can be used to attached the camera to a tree or other object

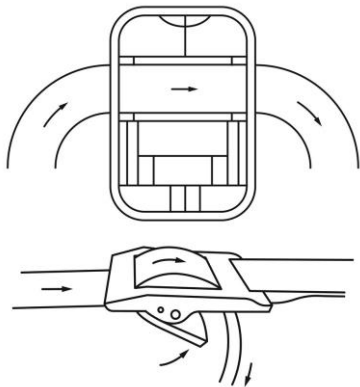

Position the camera and pull the loose end of the strap until the camera is firmly secured. To release the strap again, pull at the tab of the strap.

MOUNTING BRACKET

You can mount the camera permanently on a wall or tree using the below fasteners supplied with this product.

1. Tripod screw
2. Lock nut
3. Pivot bolts
4. Mounting holes
5. Hex Key
6. Wall plugs
7. Mounting screws



Installation

Tools required (not included)

- Drill
- 6 mm drill bit
- Phillips head screwdriver

Please Note:

1. The supplied wall plugs are only suitable for mounting on concrete and stone.
2. The camera can be tighten with the “Lock nut” .
3. The camera positioning can be adjusted by loosening and tightening the “Pivot bolts”.
4. The assembly material used must be suitable for the respective location. If in doubt, consult a professional.

CAMERA OPERATION

MODES

The camera has 4 modes for the camera move the switch to select between these. These modes will allow you to operate the camera for your specific purpose.

OFF Mode

This will turn off the camera.

IRAIM Mode

IRAIM (Infra-Red AIM) this will allow to camera to record only when motion is detected, it will record according to your Delay and Resolution settings. This mode is suitable for capturing moving objects such as animals or people.

Setup Mode

This will allow you to change some settings on the camera.



1. Press the “M” menu button to go through the different settings.
2. Use the “OK” button to enter the setting and the “Up/Down” buttons to change the setting.
3. Press the “M” button again to confirm the setting

IMAGE	MENU	FUNCTION
12:00	Time	Adjusts the time
2018	Year	Adjust the year
3/19	Month/Day	Adjust the Month and Day
Clr	Clear	Deletes all the files in the memory card. 【YES】 / 【NO】
Id	ID	Allows you to set an ID number for different locations you may use the camera in. The ID



		<p>number will be shown on the date stamp in the picture so you know which location the photo was from:</p> <p>【1】 / 【2】 / 【3】 / 【4】 / 【5】 / 【6】 / 【7】 / 【8】 【9】</p>
BA3	Battery	<p>Displays battery level:</p> <p>BA3 – Full</p> <p>BA2 – Half Full</p> <p>BA1 - Low</p> <p>BA0 – No battery camera will shutdown</p>

AUTO Mode

Switching to AUTO mode will initiate a 5sec count down before the camera proceed to recording of photos or videos



depending on what has been set on the “Resolution” setting.

RESOLUTION Setting

The camera has 4 resolutions available for you to record your photo/video, use the switch to select your preference.

Please note the video length for each video is 10 seconds.

VID: Video with low Resolution. 【720P 1280*720】

HI: High Resolution. 【8M】

Lo: Low Resolution. 【5M】

VGA: Video with high Resolution. 【VGA 640*480】

DELAY

The delay switch will allow you to set the time in between photos taken by the camera. Once the IR sensor has been



activated and a photo has been taken it will wait 1min, 5min, 10min or 30min before it resets and a new photo can be taken.

AV OUTPUT

The camera can transfer the video signal to an external monitor or a television. Please follow below instructions to operate.

1. Connect the camera to the TV via provided AV cable.
2. Turn on the TV and set it to AV mode.
3. Turn on the camera, switch the Mode Button to IRAIM or SETUP or AUTO
4. Upon successful connection these letter “PLb” will appear on the camera LCD screen, a photo or video image will appear on the TV.
5. Use the “UP” or DOWN” button to scroll through recorded photos or video.
6. Press “OK” to Play



CONNECTING TO A COMPUTER

1. Use the supplied USB cable to connect your camera to your computer.
2. After connected to the computer “USB” will appear on the screen of the camera.
3. Once inserted the computer the removable disk icon should be displayed on screen. The following menu should appear on your computer. From here you can Import or view all your files

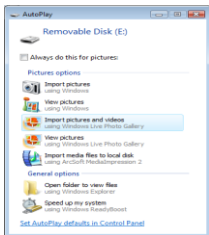

Files stored on the camera are located in the folder

named "DCIM".

4. Copy the photos or files to your computer.

Note: when watching the videos on your computer, please ensure you are using the latest version of your media player.

TROUBLESHOOTING

Problem	Solution
The exposure from the sun makes my images not good.	Place your camera in a North or South facing location this will help to prevent exposure issues from the sun.
SD Card not capturing images/video	Please check that your SD is suitable and format it before using

<p>AV input for TV</p>	<p>Check your TV manual on how to connect AV cables. Some TV may require a composite break-out cable or adapter which is not include in the product</p>
<p>I cannot upload images to the PC</p>	<p>Check all cable connections are secured.</p>
<p>The product does not respond</p>	<p>Reset the camera by removing the batteries for 1 minute, then put the batteries back and turn on.</p>
<p>The video files are very slow and bad resolutions when playing on my computer</p>	<p>Please ensure you have downloaded the latest version of your media player, or try such programs as VLC media player, Windows media, QuickTime.</p>

WARRANTY

OZtrail warrants this product against defects for a period of one year from the date of purchase. OZtrail will repair or replace the product, at its discretion, should a warrantable defect arise within the warranty period. If the exact model is unavailable a model of equivalent nature will be substituted at our discretion. This warranty excludes faults and failures caused by improper use and abuse; fair wear and tear; or failure to follow instructions regarding care and maintenance. Products used for a commercial nature are not covered by this warranty against defects. A warranty may be claimed by returning the product to its place of purchase, with a detailed proof-of-purchase clearly showing the date and detail of the purchase.



You may also contact OZtrail Leisure Products, by phone: 1300 362 921, or in writing: PO Box 1110, Eagle Farm QLD 4009, by email: warranty@oztrail.com.au. The benefits under OZtrail's warranty against defects are in addition to other rights and remedies under law in relation to goods.

Our goods come with guarantees that cannot be excluded under the Australian Consumer Law. You are entitled to a replacement or refund for a major failure and for compensation for any other reasonably foreseeable loss or damage. You are also entitled to have the goods repaired or replaced if the goods fail to be of acceptable quality and the failure does not amount to a major failure.

For more detailed information and an explanation of these terms see www.oztrail.com.au/warranty



Designed by:

OZtrail Leisure Products

71 Charles Ulm Place,

Eagle Farm, QLD 4009

AUSTRALIA

P 1300 362 921

www.oztrail.com.au

facebook.com/OZtrailAustralia

